



## Broadband to Optical Fibre Transmit Module

**Settings**  
Controlled by 5 position switch with power & status indicator lights

**Compact EMC sealed standalone housing with RF monitoring port**

**500 to 3150 MHz**  
S-Band input converted to Optic 1310nm

**Flexible Mounting**  
Tapped screw & through hole mounting options

- Single mode optical transmitter for RF over Fibre (RoF)
- A resilient solution for satellite teleports with transition distances up to 10km
- Has monitor port
- Can provide LNB powering 13/18V, 22kHz at up to 500mA total current
- Used in conjunction with S-band RX module SRY-RX-S4-488

Available with Optical Connectors:

- FC/APC
- SC/APC

or RF Connectors:

- 50 Ω SMA

RF Parameters		
Frequency Range	500 to 3150 MHz	
Flatness in Fixed Gain Mode	±1.5 dB 850 to 2150 MHz ±2.5 dB 850 to 2450 MHz ±3.0 dB 500 to 3150 MHz ±0.25 dB, any 36 MHz > -50dBm ±0.5 dB, any 36MHz i/p < -50dBm	Full TX &RX link with 10km fibre link using SRY-TX-S4-487. Fixed gain mode.
Flatness in AGC mode	±1.5 dB 850 to 2150 MHz ±2.5 dB 850 to 2450 MHz ±5.5 dB 500 to 3150 MHz ±0.25dB, any 36MHz ±0.5 dB, any 36MHz i/p < -50dBm	Full TX &RX link with 10km fibre link using SRY-RX-S4-288 in AGC mode. NOTE- In AGC mode the wideband gain control results in sharp increase in gain above 2.5GHz.
Return Loss	18 dB typ., 10 dB min	Only Available in SMA 50 ohm connectors.
Monitor port	-20 ± 3 dB	Mounted on module
OIP3	Typical 17 dBm Worst Case 14 dBm	<b>Test condition:</b> 1m fibre 10 dB gain, -22 dBm tones at 2150 and 2152 MHz
CNR (in any 36MHz)	Typical -50 dB Worst Case -45 dB	<b>Test condition:</b> 1m fibre -10 dBm RF i/p power, -10 dBm RF o/p total power.
NF	Typical 10 dB Worst Case 12 dB	<b>Test condition:</b> 1 m fibre, -50 dBm RF i/p power, -10 dBm o/p power
Group Delay variation	2ns over full band 1ns over any 36MHz.	
SFDR	105 dB/Hz <sup>2/3</sup> typ., 100 dB/Hz <sup>2/3</sup> min	<b>Test condition:</b> 1m fibre 10 dB gain, -22 dBm tones at 2150 and 2152 MHz
IMD3	-65 dBc typ., -60 dBc min.	<b>Test condition:</b> 1m fibre 10 dB gain, -22 dBm tones at 2150 and 2152 MHz
RF Input Signal Range	-60 to -10 dBm (total power)	Operational i/p range
Max RF input	16dBm total power	Damage level, NOT operational.

### Broadcast



### Marine Oil & Gas



### SNG & VSAT



### Satellite Teleport





**Technical specifications and operating parameters**

Optical Parameters		
Laser Type	DFB	Optical isolator for improved performance
Optical Wavelength	1310 ± 10 nm	
Optical Power output	4.5 ±2.5 dBm	
Optical Connectors	FC/APC SC/APC	Single mode fibre Use angle polish connectors only
Non RF Parameters		
Module swap	Hot swap	
Power supply voltage	12V ±1V	Single or dual redundant power
Power consumption	15W typical	With 18V 500 mA LNB power
LNB power	18/13V ±5 %, 500 mA max	Short circuit current 750 mA max.
MTBF	>120,000 hours	Module MTBF

Environmental conditions		
Operating Temperature	-20°C to +65°C	Mount away from sources of heat. Forced air cooling may be required dependant on application.
Storage Temperature	-40°C to +90°C	
Location	Indoor use	Outdoor use as part of ETL ODU only
Humidity	20 to 90% non-condensing	Relative Humidity
Altitude	10,000 ft AMSL operational 30,000 ft AMSL storage/transport	Above mean sea level
Mass	0.35 Kg typical	

Control, Monitoring & Alarms			
Control	1	LNB on/off	
DIP Switch	2	LNB 13/18 v	
Position	3	LNB 22 kHz on/off	Remove cover to access DIP switch
	4	AGC on/Gain fixed	
	5	Reserved	
Indicator lights			
Power		Module powered	
Status Green		Module OK	
Status Red		Internal monitoring alarm	
Monitoring includes		Laser Optical Output Power Status of amplifier stages Module temperature	Monitored in each module
AGC		Factory set	Once AGC level set, gain can be fixed

**!** Operation beyond these limits may cause instantaneous and permanent damage.

**Physical Dimensions**

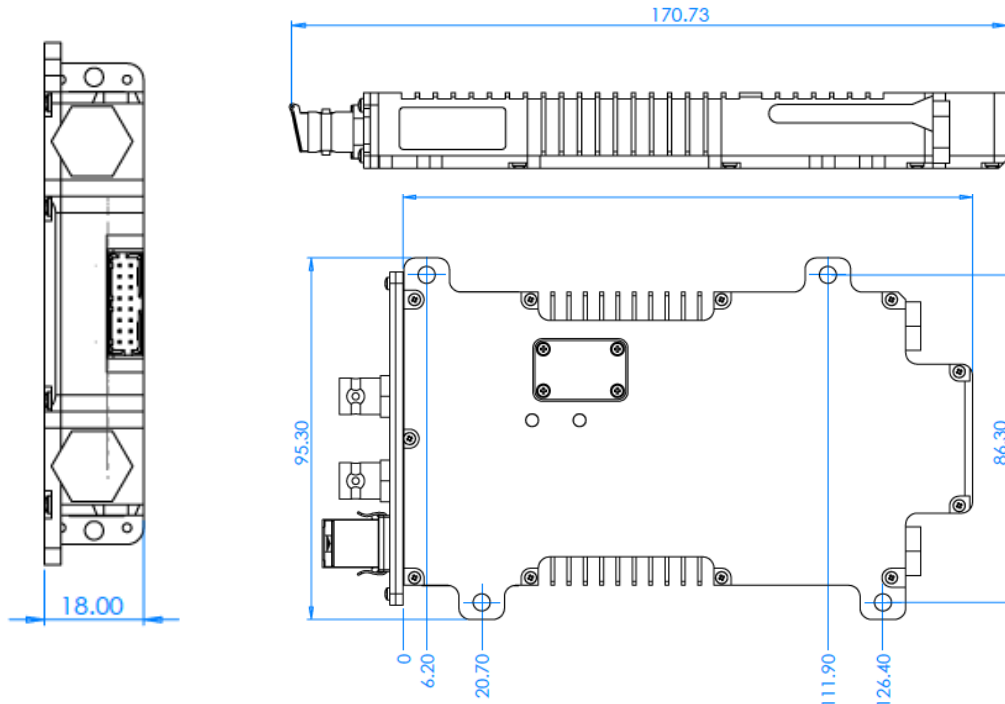

Note 1: The specification is subject to regular reviews and will be updated from time to time as part of our continuing product development and improved spec accuracy.  
Note 2: Operation beyond the quoted limits stated above may cause instantaneous and permanent damage.